



## SUPPLY CHAIN MANAGEMENT

For some time now, Supply Chain Management has had few solutions for real time tracking the physical location of assets. Methods ranging from manual bar coding to RFID were always a balance of labor cost vs. equipment cost. Either way, it costs.

Q-Track has a novel idea: a solution that has a low labor cost *-and-* a low equipment cost at the same time. To do this, we applied our patented and award-winning NFER<sup>®</sup> tracking technology in a radically different way: Since assets do not move themselves, track the equipment moving the assets. Thus, the physical location of assets may be maintained on a real-time basis with minimal cost.

### CONCEPT:

A NFER<sup>®</sup> technology based asset tracking system determines the forklift's physical location. As the forklift driver moves assets to alternate locations, the assets are identified and the motion is tracked. Once the assets are released, the new locations are automatically updated in the logistics management database.

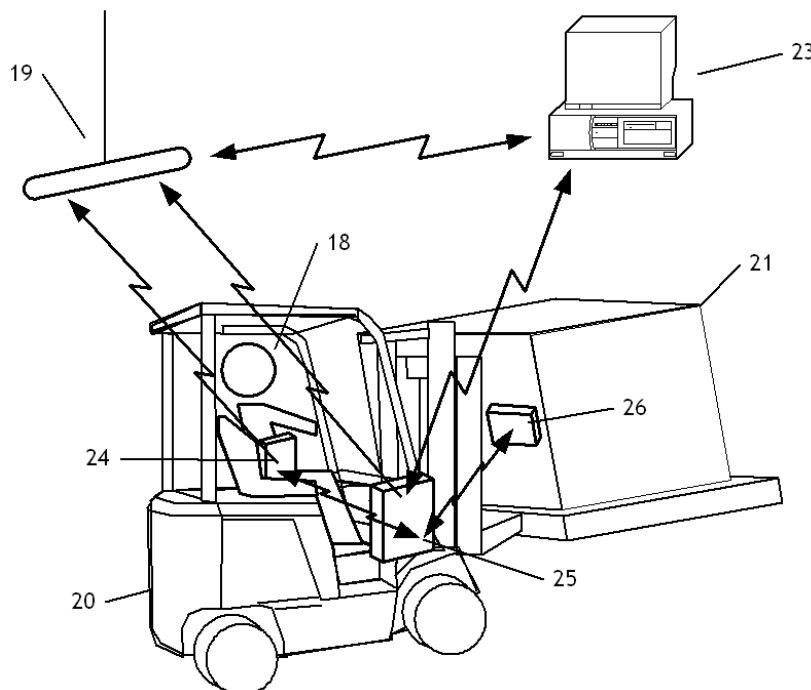

For further details, please see Q-Track's pending US patent (Publication Number 2007/0282482).



The QT<sup>™</sup>-500 Locator-Receiver localizes QT<sup>™</sup>-500 Tags to an accuracy of 1-3ft. Requiring no synchronization, the QT<sup>™</sup>-500 Locator-Receiver communicates wirelessly to the Location Server.



The QT<sup>™</sup>-500 Tag provides industrial strength real-time location for the most difficult propagation environments, indoors or outdoors.



The QT<sup>™</sup>-500 Tag mounts to the front of the forklift enabling bin level accuracy when moving pallets around a warehouse.



The Q-Track Location Server hosts the Q-Track Position Integration Engine and can send data to other computers or devices.



The location of goods and equipment can be viewed real-time over the web, on a cell phone or even a PDA.

*“The Q-Track team has turned conventional RF wisdom on its head with their counter-intuitive yet remarkably successful approach to wireless tracking. They’ve moved in the exact opposite direction of the wideband, high frequency thinking that dominates wireless tracking today, and achieved stunning results.”*



Dr. Kai Siwiak, Author,  
**UWB Radio Technology**,  
Founder, CEO,  
TimeDerivative, Inc.  
Dan Noble Fellow,  
Motorola Corp.  
Over 70 Patents in Wireless

## THE BENEFIT:

Q-Track’s novel idea to solve the problem of real-time logistics allows a relatively small tracking system to provide real-time location awareness for a large number of assets.

In a pilot installation, Q-Track used a NFER<sup>®</sup> system to track a forklift in a Just In Time Services warehouse. Using only six receivers, the system covered 50,000 sqft and tracked a forklift to bin level accuracy. For a video of the test, see: <http://www.q-track.com/VideoJITS.htm>

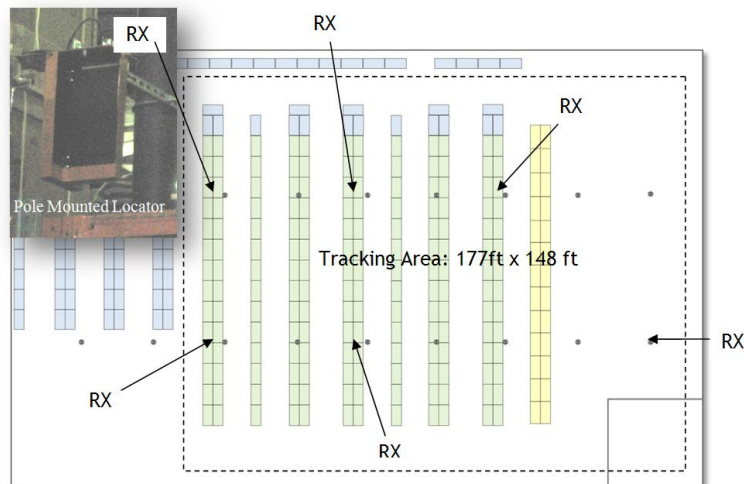

## Q-TRACK SEEKS INTEGRATORS:

Q-Track seeks an integration partner to assist in merging the NFER<sup>®</sup> forklift tracking system with an existing inventory management system.

## ABOUT Q-TRACK’S NFER<sup>®</sup> TECHNOLOGY

Q-Track is the pioneer in NFER<sup>®</sup> technology (Near-Field Electromagnetic Ranging). NFER<sup>®</sup> systems provide an RTLS (Real-Time Location System) solution for the most challenging environments. By operating at low frequencies and by utilizing differences between electric waves and magnetic waves, this breakthrough technology is significantly more accurate at longer ranges than alternatives. In complicated indoor environments, NFER<sup>®</sup> systems can localize a tag to an average accuracy of 0.3-1m (1-3ft) at ranges up to about 50m (160ft) depending on the environment.

Contact Jerry Gabig [j.gabig@q-track.com](mailto:j.gabig@q-track.com) (256)489-0075.

The Q-Track Corporation ©2009; All rights reserved.

“Q-Track,” “QT,” and “NFER” are trademarks or registered trademarks of the Q-Track Corporation.  
The Q-Track Corporation; 3414 Governors Dr. SW, Suite Q; Huntsville, AL 35805; (256) 489-0075; [www.Q-Track.com](http://www.Q-Track.com)